

# Type AIR-GEAR

## Alternative rotary actuator for high torques



- for all valves with high torques
- compact design

Range of application:  
-10 < T < 90°C  
others on request

### Design characteristics

- double and single acting
- cost saving through standard components
- variable end positions 0° - 360°
- adjustable opening and closing speed
- patented cardanic AZ coupling
- plug adjustment freely accessible
- multi position actuator

### Options

- position feedback
- declutchable gear box
- locking devices
- flange extension
- control
- endposition damping
- ATEX design
- on-site operation

# Type AIR-GEAR

## Technical information

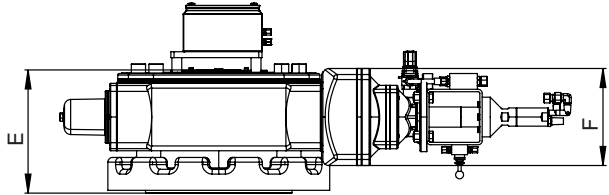
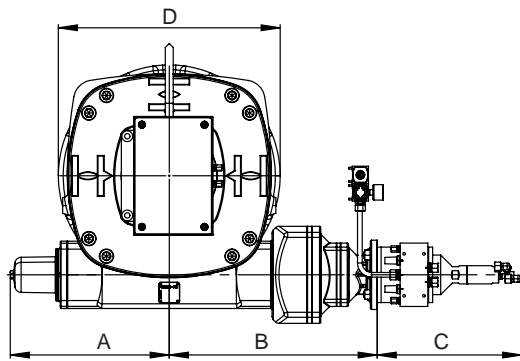

AIR-GEAR	torque Plug valve [Nm]	air pressure p [bar]	t/90° [sec]	M <sub>Actuator</sub> [Nm]	flange	A [mm]	B [mm]	C [mm]	D [mm]	E [mm]	F [mm]	weight [kg]
8000-66	≤ 8.000	3,5	72	6.293	F-16 / F-25	194	264	510	300	158	175	51
		<b>4,5 (norm)</b>	<b>54</b>	<b>8.096</b>								
		5,0	42	9.944								
		6,0	36	11.704								
15000-66	≤ 15.000	3,5	72	10.868	F-25 / F-30	290	340	510	330	170	160	96
		<b>4,5 (norm)</b>	<b>54</b>	<b>14.000</b>								
		5,0	42	17.176								
		6,0	36	20.216								
30000-66	≤ 30.000	3,5	236	21.736	F-30 / F-35	367	470	510	415	211	210	165
		<b>4,5 (norm)</b>	<b>180</b>	<b>27.963</b>								
		5,0	151	34.352								
		6,0	124	40.432								
60000-66	≤ 60.000	3,5	454	37.609	F-35 / F-40	402	525	510	516	249	245	315
		<b>4,5 (norm)</b>	<b>353</b>	<b>48.392</b>								
		5,0	295	59.438								
		6,0	244	70.000								
80000-66	≤ 80.000	3,5	454	46.475	F40	552	682	510	680	350	480	638
		<b>4,5 (norm)</b>	<b>353</b>	<b>59.800</b>								
		5,0	295	73.450								
		6,0	244	86.450								
125000-66	≤ 125.000	3,5	925	94.523	F-48	766	826	510	860	368	480	1110
		<b>4,5 (norm)</b>	<b>720</b>	<b>121.624</b>								
		5,0	563	149.386								
		6,0	498	175.826								
		7,0	471	189.707								

\*) valve flang acc. to ISO 5211